

MODELS	LIFTING MOMENT	SLEWING ANGLE	SLEWING TIME	WORKING PRESSURE	CRANE WEIGHT	OIL FLOW	RECOMMENDED TRACTOR
	tm	°	s/180°	bar	kg	l/min	hp
HB10 FFB	0.5	330	4	90	175	12	25 - 65
HB15 FFB	1.0	330	4	160	175	12	25 - 65
HB50 FFB	4.8	380	18	275	570	15	80

Features

MODELS	HB10 FFB	HB15 FFB	HB50 FFB
Structural design in accordance with: EN12999	●	●	●
Quality ISO9001:2008 certified	●	●	●
Easy to use and maintain	●	●	●
Long life painting	●	●	
4 functions control valve by Walvoil	●	●	
7 functions control valve by Hydrocontrol			●
Rack and Pinion heavy duty slewing	●	●	
Double rack and pinion heavy duty slewing			●
Cable controls	○	○	
Safety valves on cylinders	○	○	●
Floating device	●	●	●
Internal rubber hoses	●	●	
Tenifer QPQ treatment on pins	●	●	
Hexagonal boom	●	●	●
Internal extension cylinder			●
3 Jaws grab	○		
4 jaws grab		○	
Box grab			○
Oil Tank	○	○	○
Hyva Piston pump	○	○	○
Trac Power	○	○	○
Stabilizers			○

● Standard ○ Optional

www.hyvacrane.com
www.hyva.com

FFB
LINE



HYVA CRANE

HYVA Holding B.V.
 Antonie van Leeuwenhoekweg 37
 2408 AK Alphen aan den Rijn
 The Netherlands
 Telephone: (31)172 - 42 35 55
 Telefax: (31)172 - 43 31 96
 info@hyva.com

Dealer:

FFB LINE

**SPECIALIZED CRANES
 FOR AGRICULTURAL TRACTORS**

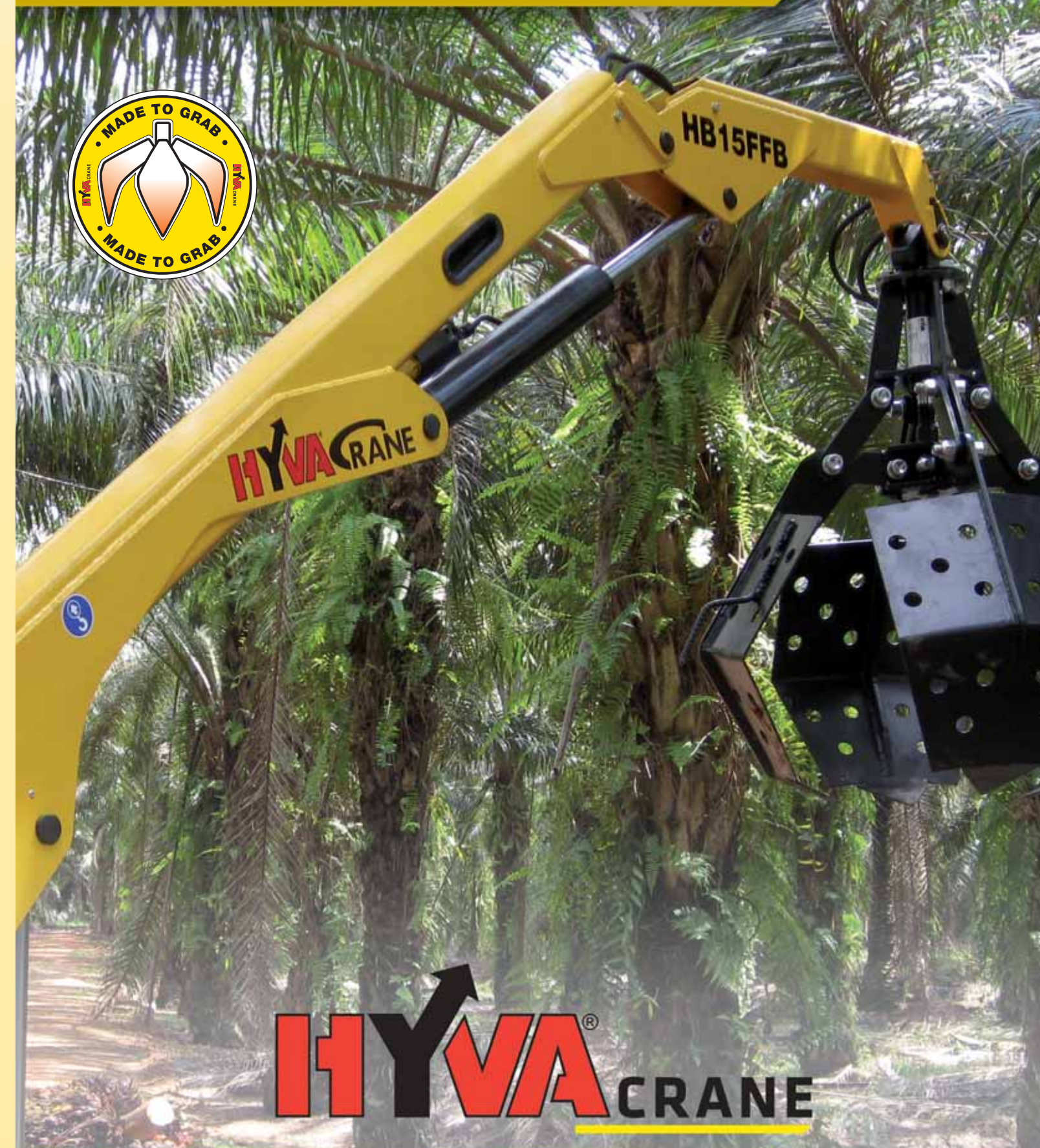

HYVA CRANE

FFB

Easy and Safe



Easy to use and maintain
All the greasing point are in a easy to access position.



4 functions control valve by Walvoil



Cable controls
Connection by cable controls allow an easy installation and a higher safety for the driver



7 functions control valve by Hidrocontrol

Strong and reliable



Structural design in accordance with: EN12999



Rack and Pinion heavy duty slewing



Quality ISO9001: 2008 certified
Production from the raw metal to the crane ready to be installed is controlled by quality procedures certified by Lloyd's register according to ISO9001.

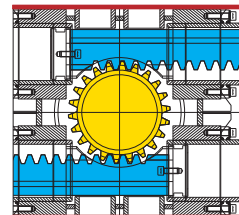

Double rack and pinion heavy duty slewing

The use of two racks spread the force across twice as many teeth on the pinion. Slewing has more strength for difficult situations.

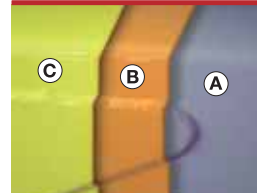

Long life painting
Painting process is made to allow the best quality possible and ensure a long crane life in all the applications and environments.
A - Iron grid sandblasting
B - Cathodic electrodeposition paint
C - Yellow polyester powder paint

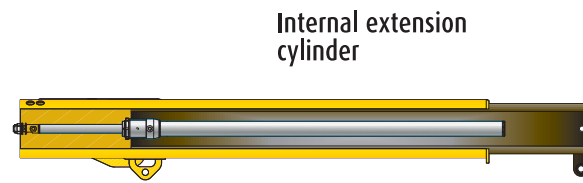

Internal extension cylinder



Hexagonal boom
The use of this technology brings superior performance, reduced maintenance, and less adjustment.

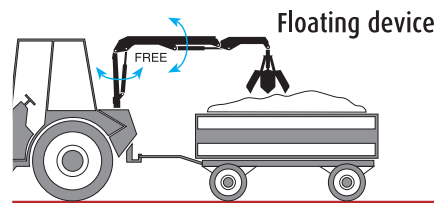

Floating device

Full packages



3 jaws grab
Self weight: 35 kg
Capacity: 50 dm³



box grab
Special attachment for bulk material



4 jaws grab
Self weight: 75 kg
Capacity: 100 dm³



Oil tank
Steel oil tank made to be installed on the back of the tractor including oil filter and level indicators.

HB10 FFB - Single fruit collection



HB15 FFB - Multiple fruit collection



HB50 FFB - Bulk material



Dimensions

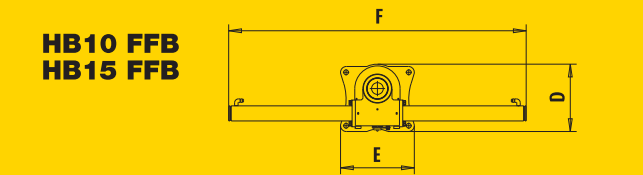
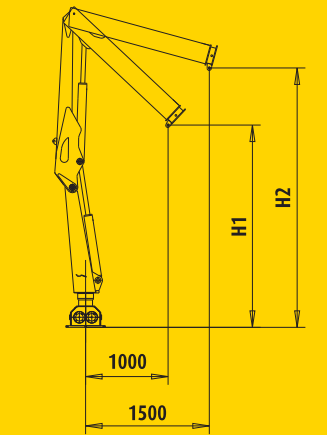
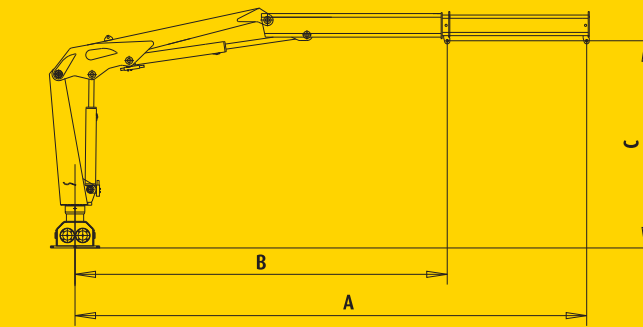

**HB10 FFB
HB15 FFB**

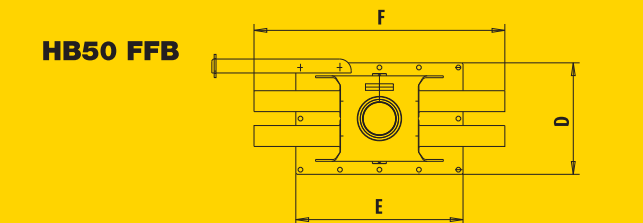

HB50 FFB

	HB10 FFB - HB15 FFB	HB50 FFB
A	N/A	5.09 m
B	2.80 m	3.73 m
C	1.24 m	2.02 m
D	290 mm	480 mm
E	318 mm	720 mm
F	1280 mm	1080 mm
H1	2047 mm	2452 mm
H2	2421 mm	3145 mm



High profitability with mechanized harvesting

Fruit pickers



Harvest time



Mechanized harvesting



Harvest time

